



US009065076B2

(12) **United States Patent**  
**Lee et al.**

(10) **Patent No.:** **US 9,065,076 B2**  
(45) **Date of Patent:** **Jun. 23, 2015**

(54) **ORGANIC LIGHT EMITTING DISPLAY DEVICE AND MANUFACTURING METHOD THEREOF**

(71) Applicant: **SAMSUNG DISPLAY CO., LTD.**,  
Yongin, Gyeonggi-Do (KR)

(72) Inventors: **Hyun-Shik Lee**, Yongin (KR);  
**Kyu-Seok Kim**, Yongin (KR)

(73) Assignee: **SAMSUNG DISPLAY CO., LTD.**,  
Yongin, Gyeonggi-Do (KR)

(\*) Notice: Subject to any disclaimer, the term of this patent is extended or adjusted under 35 U.S.C. 154(b) by 0 days.

(21) Appl. No.: **14/018,912**

(22) Filed: **Sep. 5, 2013**

(65) **Prior Publication Data**  
US 2014/0306193 A1 Oct. 16, 2014

(30) **Foreign Application Priority Data**  
Apr. 15, 2013 (KR) ..... 10-2013-0040926

(51) **Int. Cl.**  
**H01L 51/00** (2006.01)  
**H01L 51/52** (2006.01)

(52) **U.S. Cl.**  
CPC ..... **H01L 51/5275** (2013.01); **H01L 51/5268** (2013.01)

(58) **Field of Classification Search**  
CPC ..... H01L 51/5275; H01L 51/5268; H01L 23/293; H01L 23/3135  
USPC ..... 257/40, 98, 790, 59, 72; 438/99, 34, 438/127  
See application file for complete search history.

(56) **References Cited**  
**U.S. PATENT DOCUMENTS**  
2003/0164496 A1 9/2003 Do et al.  
2012/0241771 A1 9/2012 Kato et al.  
2012/0256218 A1\* 10/2012 Kwack et al. .... 257/98

**FOREIGN PATENT DOCUMENTS**  
KR 10-2003-0070985 A 9/2003  
KR 10-2012-0044675 A 5/2012  
KR 10-2012-0108906 A 10/2012  
\* cited by examiner

*Primary Examiner* — Tu-Tu Ho  
(74) *Attorney, Agent, or Firm* — Lee & Morse, P.C.

(57) **ABSTRACT**  
An organic light emitting display device includes a substrate, a display unit on the substrate, and an encapsulation layer on the display unit, the encapsulation layer including a plurality of alternating inorganic and organic films, at least one of the organic films being a patterned organic film, and the patterned organic film having a plurality of high refractive index portions in an organic matrix.

**9 Claims, 7 Drawing Sheets**

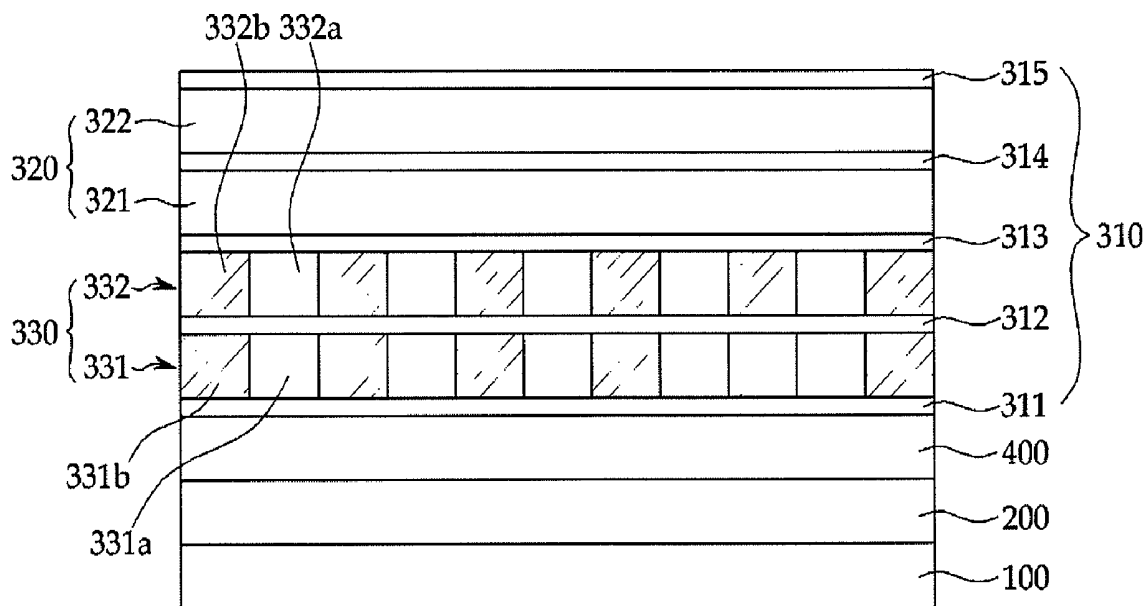

FIG. 1

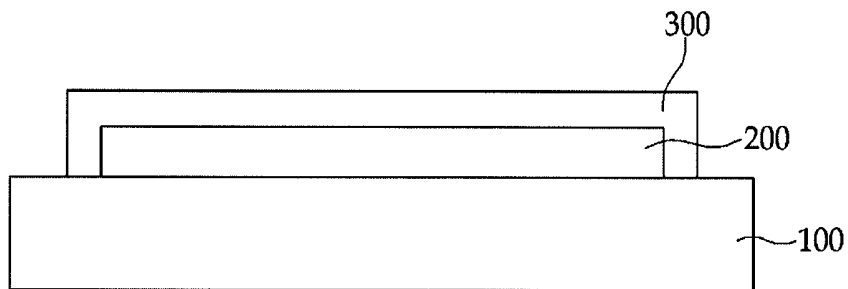

FIG. 2

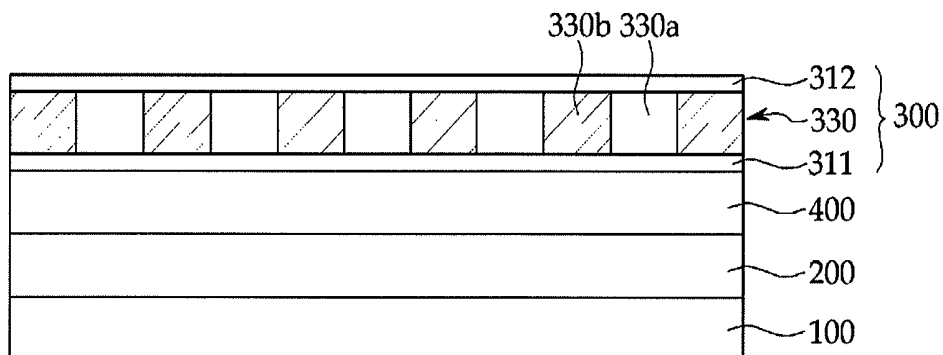

FIG. 3

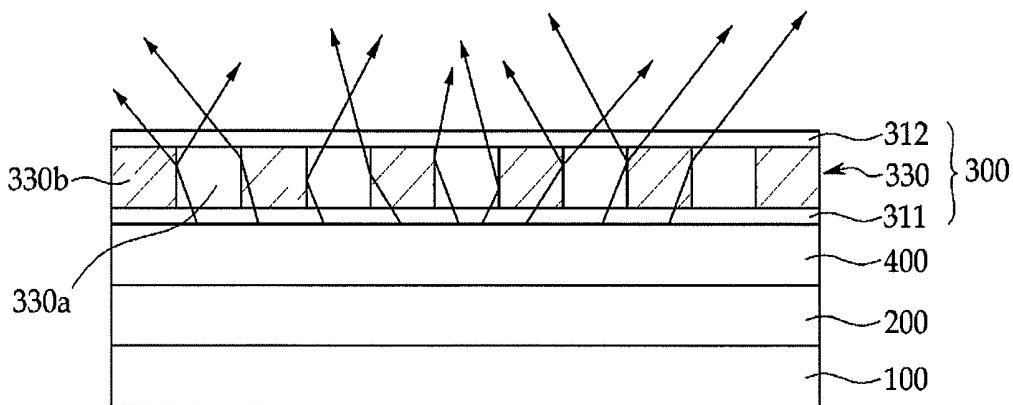

FIG. 4

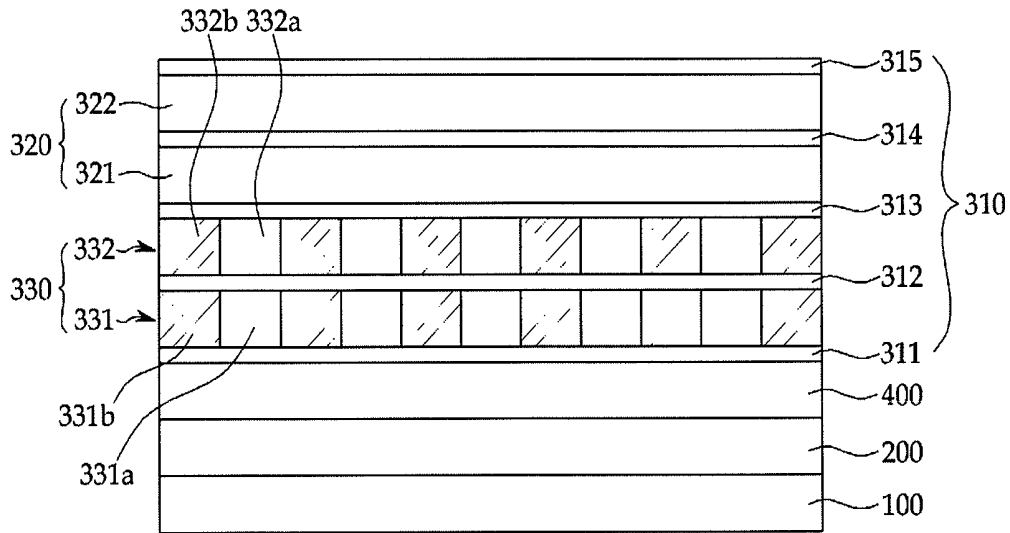
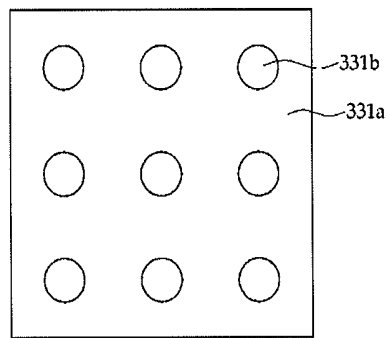
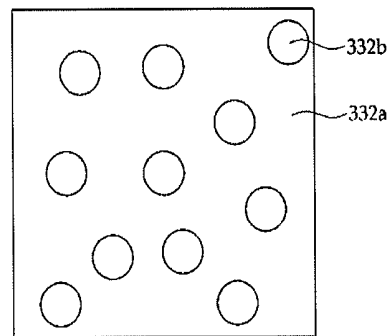

FIG. 5



(a)



(b)

FIG. 6

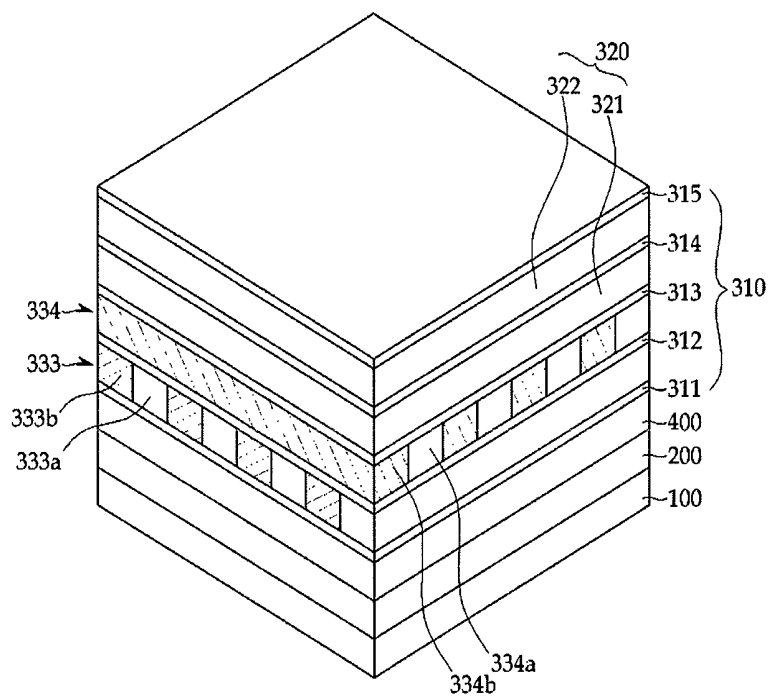

FIG. 7

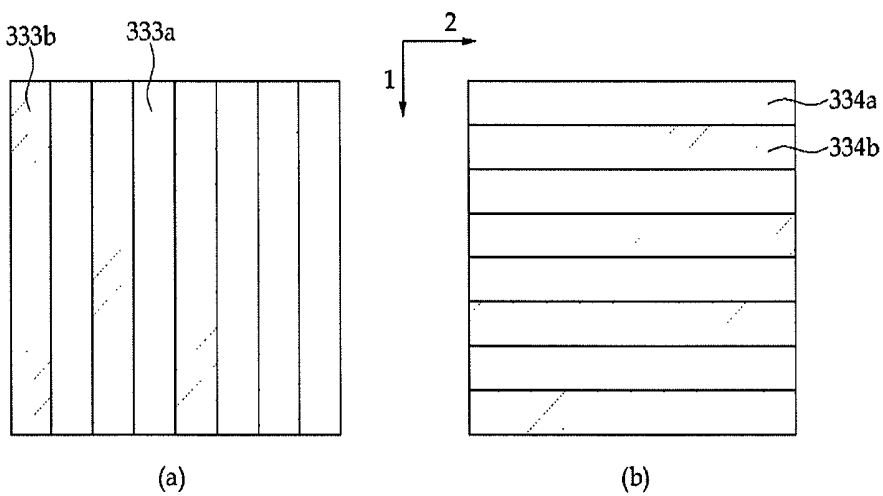

FIG. 8

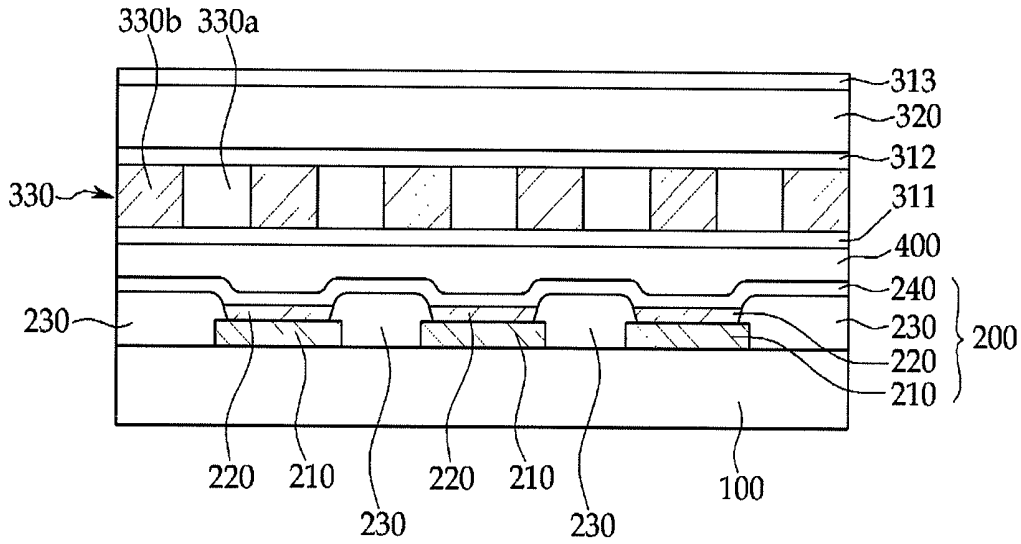

FIG. 9A

501

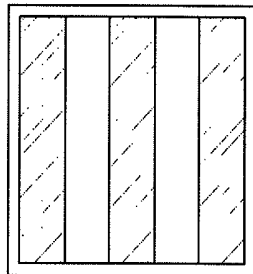
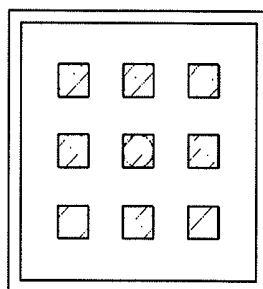

FIG. 9B

502



**FIG. 9C**

503

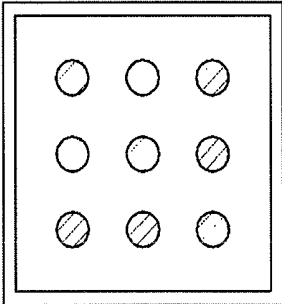

**FIG. 9D**

504

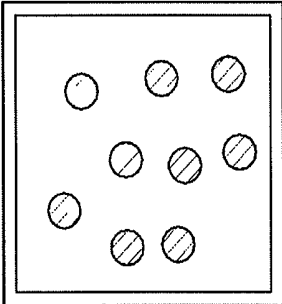

**FIG. 10A**

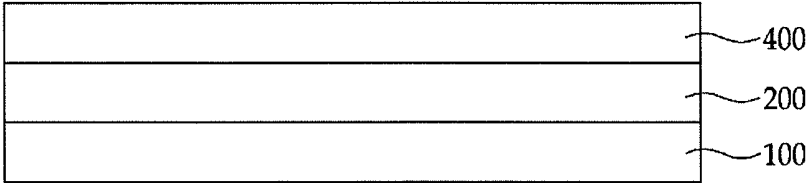

FIG. 10B

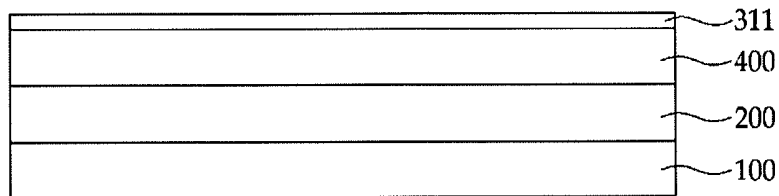

FIG. 10C

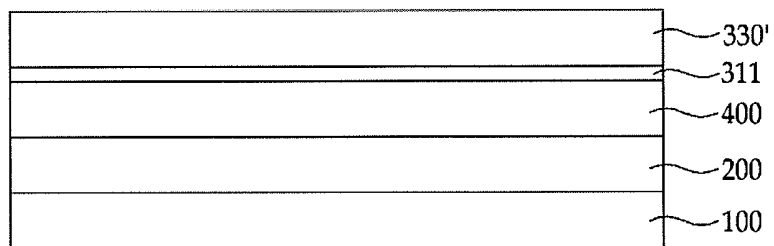

FIG. 10D

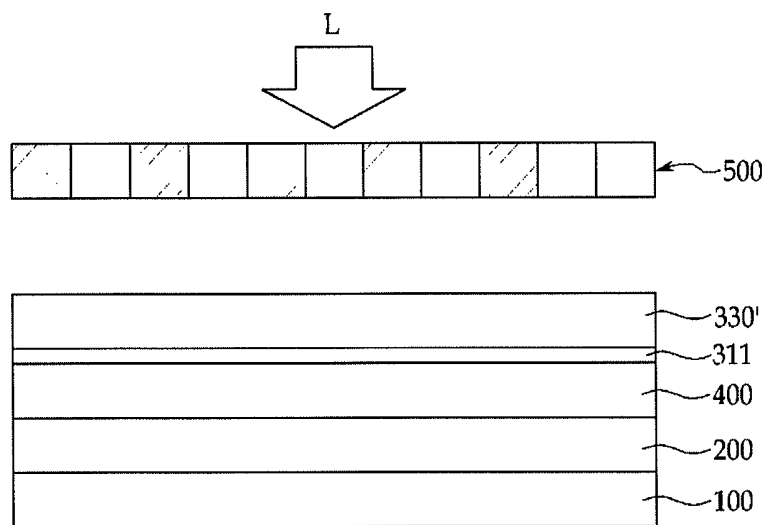

FIG. 10E

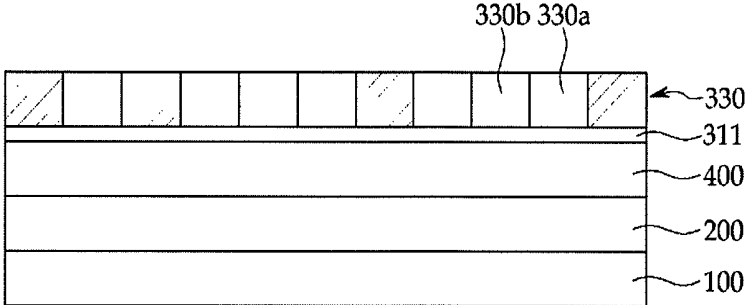
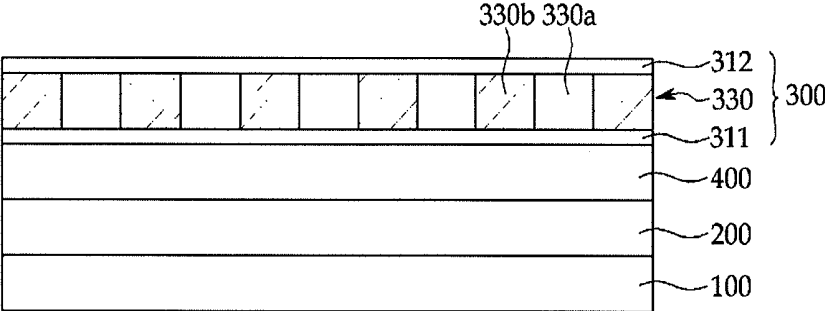

FIG. 10F



# ORGANIC LIGHT EMITTING DISPLAY DEVICE AND MANUFACTURING METHOD THEREOF

## CROSS-REFERENCE TO RELATED APPLICATION

Korean Patent Application No. 10-2013-0040926, filed on Apr. 15, 2013, in the Korean Intellectual Property Office, and entitled: "ORGANIC LIGHT EMITTING DISPLAY DEVICE AND MANUFACTURING METHOD THEREOF," is incorporated by reference herein in its entirety.

## TECHNICAL FIELD

The present disclosure relates to an organic light emitting display device and a manufacturing method thereof. More particularly, the present disclosure relates to an organic light emitting display device with a patterned organic film in a thin film encapsulation layer, thereby increasing light extraction efficiency, and to a manufacturing method thereof.

## BACKGROUND

An organic light emitting display device is a self-emission display device which has an organic light emitting diode that emits light to display an image. Since the organic light emitting display device does not require a separate light source, unlike a liquid crystal display, it is possible to reduce a thickness and a weight thereof, e.g., as compared to the liquid crystal display. Further, the organic light emitting display device exhibits low power consumption, high luminance, and rapid response speed.

The organic light emitting diode of the organic light emitting display device may include a hole injection electrode, an organic emission layer, an electron injection electrode, and a thin film encapsulation layer. In the organic light emitting diode, a hole supplied from the hole injection electrode and an electron supplied from the electron injection electrode are coupled with each other in the organic emission layer to form an exciton, and light is generated by energy generated when the exciton falls to a ground state.

## SUMMARY

The present disclosure has been made in an effort to provide an organic light emitting display device and a manufacturing method thereof with improved light extraction efficiency by forming a patterned organic film in an encapsulation layer to reduce total internal reflection generated in the organic light emitting display device.

An exemplary embodiment of the present disclosure provides an organic light emitting display device including a substrate, a display unit on the substrate, and an encapsulation layer on the display unit, the encapsulation layer including a plurality of alternating inorganic and organic films, at least one of the organic films being a patterned organic film, and the patterned organic film having a plurality of high refractive index portions in an organic matrix.

The organic matrix may include an organic material having a refractive index of about 1.45 to about 1.5.

The high refractive index portions may have a refractive index of about 1.5 to about 1.6.

The high refractive index portions may have a shape of a cylinder, a prism, a convex lens, a concave lens, or a line.

The encapsulation layer may include at least two patterned organic films.

The at least two patterned organic films may be separated by one inorganic film, and the high refractive index portions in each of the at least two patterned organic films are line shaped, the high refractive index portion in an upper patterned organic film of the at least two patterned organic films are perpendicular to the high refractive index portion in a lower patterned organic film of the two patterned organic films.

The organic matrix and the high refractive index portions may include a same material.

The display unit may include a first electrode on the substrate, an emission layer on the first electrode, and a second electrode on the emission layer.

The organic light emitting display device may further include a capping layer between the display unit and the encapsulation layer.

An exemplary embodiment of the present disclosure also provides a manufacturing method of an organic light emitting display device, the method including forming a display unit on a substrate, and forming an encapsulation layer on the display unit by forming a plurality of alternating inorganic and organic films, and at least one of the organic films being formed by selective light irradiation after the organic film is coated.

The selective light irradiation may include irradiating light through a half tone mask.

The selective light irradiation may include irradiating light from at least two light sources, such that intensity of light incident on the organic film changes due to constructive and destructive interference of light from the at least two light sources to perform the selective light irradiation.

Forming the organic films may include uniformly coating the organic films with the same material.

The selective light irradiation may be performed at least through a first mask and through a second mask, the first mask having a slit shape in a first direction, and the second mask having a slit shape in a second direction crossing the first direction.

## BRIEF DESCRIPTION OF THE DRAWINGS

FIG. 1 is a cross-sectional view illustrating an organic light emitting display device according to an exemplary embodiment of the present disclosure.

FIG. 2 is a diagram illustrating an organic light emitting display device including a patterned organic film according to the exemplary embodiment of the present disclosure.

FIG. 3 is a diagram illustrating reflection and refraction of light appearing on an interface of a high refractive index portion of a patterned organic film according to the exemplary embodiment of the present disclosure.

FIG. 4 is a diagram illustrating an organic light emitting display device including a patterned organic film according to another exemplary embodiment of the present disclosure.

FIG. 5 is a plan view of a patterned organic film according to the exemplary embodiment of the present disclosure.

FIG. 6 is a diagram illustrating an organic light emitting display device including a patterned organic film according to yet another exemplary embodiment of the present disclosure.

FIG. 7 is a plan view of a patterned organic film according to yet another exemplary embodiment of the present disclosure.

FIG. 8 is a diagram illustrating the organic light emitting display device illustrated in FIG. 2 in more detail.

FIG. 9a is a diagram illustrating a slit-shaped mask according to the exemplary embodiment of the present disclosure.

FIG. 9*b* is a diagram illustrating a quadrangular-shaped mask according to the exemplary embodiment of the present disclosure.

FIG. 9*c* is a diagram illustrating a circle-shaped mask having a regular distribution according to the exemplary embodiment of the present disclosure.

FIG. 9*d* is a diagram illustrating a circle-shaped mask having an irregular distribution according to the exemplary embodiment of the present disclosure.

FIGS. 10*a* through 10*f* are diagrams illustrating stages in a manufacturing process of an organic light emitting display device according to the exemplary embodiment of the present disclosure.

#### DETAILED DESCRIPTION

Hereinafter, exemplary embodiments of the present disclosure will be described in more detail with reference to the accompanying drawings. However, the scope of the present disclosure is not limited to the following examples and drawings. Exemplary embodiments to be described below and illustrated in the drawings may include various equivalences and modifications.

The terminology used in this specification is terms used in order to express the exemplary embodiments of the present disclosure and may depend on the intention of users or operators or the custom in the art to which the present disclosure belongs. Accordingly, the terminology needs to be defined based on details throughout this specification.

For reference, respective components and shapes thereof may be schematically drawn or exaggeratedly drawn in the accompanying drawings for easy understanding. Like reference numerals designate like elements throughout the drawings. Further, it will be understood that when a layer or an element is described as being “on” another layer or element, it may be directly disposed on another layer or element, or an intervening layer or element may also be present.

FIG. 1 is a cross-sectional view illustrating an organic light emitting display device according to an exemplary embodiment of the present disclosure.

Referring to FIG. 1, the organic light emitting display device according to the exemplary embodiment of the present disclosure may include a substrate 100, a display unit 200, and an encapsulation layer 300.

The substrate 100 may be made of various materials, e.g., a glass substrate, a quartz substrate, and/or a transparent resin substrate, and may be formed by using a flexible material. For example, a transparent resin substrate, which is usable as the substrate 100, may contain, e.g., a polyimide resin, an acrylic resin, a polyacrylate resin, a polycarbonate resin, a polyether resin, a polyethylene terephthalate resin, a sulfonic acid resin, and the like.

In a case that the organic light emitting display device is a bottom emission type, i.e., when an image is displayed toward the substrate 100, the substrate 100 is made of a light transmitting material. In the case that the organic light emitting display device is a top emission type, i.e., when an image is displayed toward the encapsulation layer 300, the substrate 100 may not necessarily be made of a light transmitting material.

The display unit 200 may include an emission layer 220 (FIG. 8). The configuration of the display unit 200 will be described below with reference to FIG. 8.

The encapsulation layer 300 may include alternately laminated organic films 320 and inorganic films 310 (FIG. 4). The configuration of the encapsulation layer 300 will be explained in more detail below with reference to FIG. 4.

FIG. 2 is a diagram illustrating a detailed organic light emitting display device according to the exemplary embodiment of the present disclosure.

Referring to FIG. 2, the organic light emitting display device according to the exemplary embodiment of the present disclosure may include the substrate 100, the display unit 200 formed on the substrate 100, and the encapsulation layer 300 formed on the display unit 200. As discussed previously, the encapsulation layer 300 may include a plurality of inorganic films 310 and a plurality of organic films 320 (FIG. 4), and the plurality of inorganic films 310 and the plurality of organic films 320 may be alternately laminated. The laminated number of the organic films 320 and the inorganic films 310 may be set by considering external light extraction efficiency and the like.

When a conventional organic light emitting display device includes a conventional encapsulation layer, which includes a multilayered structure, an optical characteristic of the conventional organic light emitting display device may deteriorate. That is, the conventional multilayered structure includes a plurality of organic and inorganic films with different refractive indices, so part of the light generated by an emission layer in the display unit may be restricted by internal total reflection, i.e., due to the different refractive indices, followed by dissipation.

Therefore, in order to prevent the light extraction efficiency from deteriorating, in the present disclosure, as illustrated in FIG. 2, a patterned organic film 330 may be included in the encapsulation layer 300. The patterned organic film 330 may be formed of at least one of the plurality of organic films 320, so the laminated structure of the alternating inorganic and organic films 310 and 320 of the encapsulation layer 300 may include the patterned organic film 330 instead of one of the organic films 320. For example, a first inorganic film 311, the patterned organic film 330, and a second inorganic film 312 may be formed, e.g., sequentially and directly on top of each other, on the display unit 200. The patterned organic film 330 may include a plurality of high refractive index portions 330*b* dispersed in a matrix 330*a*, which is made of an organic material.

In detail, the plurality of organic films 320 is relatively thick to prevent moisture vapor transmission and to provide planarization. In order to prevent the thick organic films 320 from flowing, formation of the organic film 320 may include coating an organic material 330' (FIG. 10D) on an inorganic film, followed by ultraviolet light irradiation and curing of the organic material 330' to form the organic film 320. A selective ultraviolet light irradiation, i.e., varying an amount of irradiated light in accordance with a position on the organic film, may be performed on at least one of the organic films 320 in order to form the patterned organic film 330, i.e., by the selective light irradiation.

In further detail, the coated organic material 330' has the property that a refractive index thereof increases as the amount of the ultraviolet light irradiation thereon increases. Accordingly, the patterned organic film 330 of the present disclosure may vary a refractive index of, e.g., an internal region of the organic material 330' by locally differentiating between the amounts of the ultraviolet light irradiation during the curing process. For example, a region where the amount of ultraviolet light irradiation is small may define the matrix 330*a*, which is made of an organic material, and a region where the amount of ultraviolet light irradiation is large may define the high refractive index portions 330*b* in the matrix 330*a*.

For example, a refractive index of the matrix 330*a*, which is made of an organic material, may be about 1.45 to about

1.5, and a refractive index of the plurality of high refractive index portions **330b** may be about 1.5 to about 1.6. Accordingly, due to the difference in a refractive index of the matrix **330a**, which is made of an organic material, and the plurality of high refractive index portions **330b**, light generated by the emission layer of the display unit **200** may be scattered and diffracted.

FIG. **3** is a diagram illustrating reflection and refraction of light at an interface of the high refractive index portion **330b** of the patterned organic film **330** according to the exemplary embodiment of the present disclosure. As illustrated in FIG. **3**, scattering and diffraction of light occur at the interface of the plurality of high refractive index portions **330b** with the matrix **330a**.

In detail, the matrix **330a** and the high refractive index portions **330b** may be made of the same material. Since the patterned organic film **330** has a structure in which a refractive index for each region varies depending on the amount of ultraviolet light irradiation after the patterned organic film **330** is formed of the same organic material **330'**, the patterned organic film **330** may be made of the same material, and a difference in degree of polymerization and the like may occur.

FIG. **4** is a diagram illustrating an organic light emitting display device including a patterned organic film according to another exemplary embodiment of the present disclosure.

Referring to FIG. **4**, the patterned organic film **330** may be formed at least twice or more, i.e., first and second patterned organic films **331** and **332**. For example, the display unit **200** may be formed on the substrate **100**, and a capping layer **400** may be formed on the display unit **200**. The first inorganic film **311** may be formed on the capping layer **400**, the first patterned organic film **331** may be formed on the first inorganic film **311**, the second inorganic film **312** may be formed on the first patterned organic film **331**, and the second patterned organic film **332** may be formed on the second inorganic film **312**. Further, a third inorganic film **313**, a first organic film **321**, a fourth inorganic film **314**, a second organic film **322**, and a fifth inorganic film **315** may be sequentially laminated. Each of the first and second patterned organic films **331** and **332** has a substantially same structure as that of the patterned organic film **330** in FIG. **2**. It is possible to improve light extraction efficiency by forming the patterned organic film **330** at least twice or more.

FIG. **5** illustrates plan views of the first and second patterned organic films **331** and **332** of FIG. **4**. Referring to FIG. **5**, high refractive index portions **331b** and **332b** of the patterned organic films **331** and **332**, respectively, may have any suitable shape, e.g., a cylinder, a prism, a convex lens, or a concave lens.

Further, the high refractive index portion **330b** of the patterned organic film **330** may be dispersed regularly or irregularly in the matrix **330a**, which is made of an organic material. For example, referring to FIG. **5**, the first high refractive index portion **331b** of the first patterned organic film **331** may be regularly dispersed in a first matrix **331a**, which is made of an organic material, in the shape of a cylinder, and the second high refractive index portion **332b** of the second patterned organic film **332** may be irregularly dispersed in a second matrix **332a**, which is made of an organic material, in the shape of a cylinder, e.g., a circle.

FIG. **6** is a diagram illustrating an organic light emitting display device including two patterned organic films according to yet another exemplary embodiment of the present disclosure. FIG. **7** illustrates plan views of the two patterned organic films in FIG. **6**.

Referring to FIGS. **6** and **7**, an organic light emitting display device according to another embodiment may include

two patterned organic films **333** and **334** with the second inorganic film **312** therebetween. The high refractive index portions of each of the two patterned organic films **333** and **334**, i.e., high refractive index portions **333b** and **334b**, are formed by a line type. Further, the high refractive index portion **333b** included in the lower patterned organic film **333** of the two patterned organic films **330** and the high refractive index portion **334b** included in the upper patterned organic film **334** of the two patterned organic films **330** may be disposed to cross each other.

For example, the first inorganic film **311** may be formed on the capping layer **400**, and a third patterned organic film **333**, i.e., the lower patterned organic film **333**, may be formed on the first inorganic film **311**. The second inorganic film **312** may be formed on the third patterned organic film **333**, and a fourth patterned organic film **334**, i.e., the upper patterned organic film **334**, may be formed on the second inorganic film **312**. Further, the third inorganic film **313**, the first organic film **321**, the fourth inorganic film **314**, the second organic film **322**, and the fifth inorganic film **315** may be sequentially laminated on the fourth patterned organic film **334**.

The third patterned organic film **333** may be made of a third matrix **333a**, which is made of an organic material, and a third line-type high refractive index portion **333b**. The fourth patterned organic film **334** may be made of a fourth matrix **334a**, which is made of an organic material, and a fourth line-type high refractive index portion **334b**. The high refractive index portions **333b** and **334b** may have a shape like a slit when viewed from above, as illustrated in FIG. **7**. That is, the line-type may be a long slit having a predetermined height and thickness. Accordingly, each of the matrices **333a** and **334a**, which are made of an organic material, and the corresponding high refractive index portions **333b** and **334b** may be repeated in an elongated slit shape.

The third high refractive index portion **333b** and the fourth high refractive index portion **334b** may be formed to cross each other when viewed from above. As illustrated in FIG. **7**, the third high refractive index portion **333b** may be formed along a first direction, and the fourth high refractive index portion **334b** may be formed along a second direction orthogonal to the first direction. Accordingly, the third high refractive index portion **333b** and the fourth high refractive index portion **334b** may be orthogonal to each other, and scattering and diffraction of light generated in the emission layer **220** of the display unit **200** may increase. An angle, at which the third high refractive index portion **333b** and the fourth high refractive index portion **334b** cross each other, may be formed in various manners.

The thin film materials, which are usable as the inorganic film **310**, the organic film **320**, and the patterned organic film **330**, and a laminating method of the inorganic film **310**, the organic films **320**, and the patterned organic film **330** may be any suitable materials and methods.

For example, the thin film material which is usable as the inorganic film **310** may contain, e.g., at least one of silicon nitride, aluminum nitride, zirconium nitride, titanium nitride, hafnium nitride, tantalum nitride, silicon oxide, aluminum oxide, and titanium oxide. The thin film material which is usable as the organic film **320** may contain, e.g., at least one of epoxy, acrylate, urethane acrylate, polyurea, polyacrylate, PTCDA, BPDA, and PMDA. The patterned organic film **330** may be formed by using any suitable thin film material of the organic film **320** which is usable as ultraviolet light curing resin.

The inorganic film **310** and the organic film **320** may be formed by using, e.g., a spin coating process, a printing process, a sputtering process, a chemical vapor deposition

(CVD) process, an atomic layer deposition (ALD) process, a plasma enhanced chemical vapor deposition (PECVD) process, a high density plasma-chemical vapor deposition (HDP-CVD) process, a vacuum deposition process, and the like, according to a material for forming the encapsulation layer **300**.

Referring back to FIG. 6, the capping layer **400** may be disposed between the display unit **200** and the encapsulation layer **300**. The capping layer **400** may be made of, e.g., a transparent material having ultraviolet light absorbing capacity.

FIG. 8 is a detailed diagram of the organic light emitting display device in FIG. 2.

Referring to FIG. 8, the display unit **200** may include a first electrode **210** formed on the substrate **100**, a pixel defining layer (PDL) **230** formed between the first electrodes **210**, the emission layer **220** formed on the first electrode **210**, and a second electrode **240** formed on the emission layer **220**. The first electrode **210** and the second electrode **240** may contain any suitable materials.

In the case where the organic light emitting display device is a top emission type, the first electrode **210** may contain at least one of gold (Au), platinum (Pt), nickel (Ni), tungsten (W), chromium (Cr), molybdenum (Mo), iron (Fe), cobalt (Co), copper (Cu), palladium (Pd), titanium (Ti), and a compound thereof. In addition, the second electrode **240** may contain at least one of indium tin oxide (ITO) and indium zinc oxide (IZO), which are transparent conductive oxides.

In the case where the organic light emitting display device is a bottom emission type, the first electrode **210** may contain at least one of indium tin oxide (ITO) and indium zinc oxide (IZO), which are transparent conductive oxides having a high work function. In addition, the second electrode **240** may be made of metal having a low work function, such as an alkali metal, e.g., lithium (Li) and/or cesium (Cs), alkaline earth metal, e.g., magnesium (Mg), calcium (Ca), and/or strontium (Sr), and a compound thereof.

The emission layer **220** may include a red emission layer, a green emission layer, and a blue emission layer. The emission layer **220** may be made of a low molecular organic material or a high molecular organic material.

The pixel defining layer **230** may be made of a material having an insulation property to partition the first electrodes **210** into pixels. In detail, the pixel defining layer **230** is disposed at an edge of the first electrode **210** to partition the first electrodes **210** by a pixel and define pixel areas. The pixel defining layer **230** covers the edge of the first electrode **210**.

FIG. 9a is a diagram illustrating a slit-shaped mask according to the exemplary embodiment of the present disclosure. FIG. 9b is a diagram illustrating a quadrangular-shaped mask according to the exemplary embodiment of the present disclosure. FIG. 9c is a diagram illustrating a circle-shaped mask having a regular distribution according to the exemplary embodiment of the present disclosure. FIG. 9d is a diagram illustrating a circle-shaped mask having an irregular distribution according to the exemplary embodiment of the present disclosure. FIGS. 10a-10f are diagrams illustrating stages in a manufacturing process of the organic light emitting display device according to the exemplary embodiment of the present disclosure.

Referring to FIGS. 9a-10f, another exemplary embodiment of the present disclosure provides a manufacturing method of the organic light emitting display device. That is, the manufacturing method may include forming the display unit **200** on the substrate **100**, and forming the encapsulation layer **300** on the display unit **200**.

Forming of the encapsulation layer **300** may include alternately forming the organic films **320** and the inorganic films **310**. When forming the organic films **320**, at least one organic film may be treated for a selective light irradiation after the organic film is coated.

In performing the selective light irradiation, a half tone mask **500** (FIG. 10D) may be used. The half tone mask **500** may control the amount of light irradiation, and the half tone mask **500** may be any one of a slit-shaped mask **501**, a quadrangular-shaped mask **502**, a circle-shaped mask **503** having a regular distribution, a circle-shaped mask **504** having an irregular distribution, and the like (FIGS. 9a-9d). In FIGS. 9a-9d and 10D, a dark portion of the slit shape, the quadrangular shape, and the circle shape in the half tone mask **500** may transmit more light, and the remaining white portion may transmit less light. The four masks given as an example of the half tone mask **500** are only exemplified, and those skilled in the art can use a modified half tone mask when necessary.

The half tone mask **500** may be disposed above an organic material **330'** to be patterned, and light may be fully irradiated to the organic material **330'** through the half tone mask **500**. Meanwhile, when performing the selective light irradiation, light is irradiated by more than two light sources. Therefore, intensity of light incident on the organic material **330'** may change according to constructive or destructive interference of the more than two light sources, so that the selective light irradiation may be performed. That is, the patterned organic film **330** may be formed by controlling interference of light without a mask.

The light irradiation type using the interference of the light may be a kind of hologram lithography. The hologram lithography is a technique of forming a pattern by multibeam interference. For example, in the case of two beam interference, an area where intensity of light increases by constructive interference occurring when lights irradiated in two directions overlap and another area where intensity of light is zero by destructive interference may be periodically produced. In the case of multibeam interference, many lights overlap one another and a circular shape or a specific shape may be embodied.

Meanwhile, performing the selective light irradiation may be conducted at least twice, and the selective light irradiation may be performed by disposing a slit-shaped mask in one direction over the organic film, and thereafter by disposing another slit-shaped mask in a different direction crossing the one direction over the organic film. Specifically, the organic film **320** is first coated. The slit-shaped mask in one direction is disposed over the organic film **320**, and then the selective light irradiation is performed. The inorganic film **310** is formed on the patterned organic film **330** which is formed by the selective light irradiation, and thereafter another organic film **320** is coated again on the inorganic film **310**. After that, a slit-shaped mask in different direction crossing the one direction is disposed above the other organic film **320** so as to perform the selective light irradiation. For example, as illustrated in FIG. 7, the third patterned organic film **333** and the fourth patterned organic film **334** may be formed. Meanwhile, the patterned organic film **330** may be uniformly coated with the same material.

Referring to FIGS. 10a-10f, an exemplary embodiment of the manufacturing method of the organic light emitting display device including the patterned organic film **330** is as follows. The display unit **200** is first formed on the substrate **100**, and then the capping layer **400** may be formed on the display unit **200** (FIG. 10a).

After that, the first inorganic film **311** may be formed on the capping layer **400** (FIG. **10b**). The organic material **330'** is coated on the first inorganic film **311** (FIG. **10c**), followed by disposing the half tone mask **500** above the organic material **330'** so that light may be irradiated (FIG. **10d**). Then, the patterned organic film **330** may be formed on the first inorganic film **311**.

The patterned organic film **330** may include the matrix **330a** which is made of an organic material and the plurality of the high refractive index portions **330b** due to the selective light irradiation (FIG. **10e**). The second inorganic film **312** may be formed on the patterned organic film **330** (FIG. **10f**).

According to the exemplary embodiments of the present disclosure, it is possible to improve light extraction efficiency to the outside and reduce power consumption, by disposing a patterned organic film in an encapsulation layer. As described above, the organic light emitting display device and the manufacturing method thereof are only exemplified, and those skilled in the art can understand that the scope of the present disclosure may include various modifications and equivalent embodiments therefrom.

From the foregoing, it will be appreciated that various embodiments of the present disclosure have been described herein for purposes of illustration, and that various modifications may be made without departing from the scope and spirit of the present disclosure. Accordingly, the various embodiments disclosed herein are not intended to be limiting, with the true scope and spirit being indicated by the following claims.

What is claimed is:

1. An organic light emitting display device, comprising:  
a substrate;  
a display unit on the substrate; and  
an encapsulation layer on the display unit, the encapsulation layer including a plurality of alternating inorganic and organic films, at least one of the organic films being a patterned organic film, and the patterned organic film having a plurality of high refractive index portions in an organic matrix,

wherein the high refractive index portions include an organic material.

2. The organic light emitting display device of claim 1, wherein the organic matrix includes an organic material having a refractive index of about 1.45 to about 1.5.

3. The organic light emitting display device of claim 1, wherein the high refractive index portions have a refractive index of about 1.5 to about 1.6.

4. The organic light emitting display device of claim 1, wherein the high refractive index portions have a shape of a cylinder, a prism, a convex lens, a concave lens, or a line.

5. The organic light emitting display device of claim 1, wherein the encapsulation layer includes at least two patterned organic films.

6. The organic light emitting display device of claim 5, wherein:

the at least two patterned organic films are separated by one inorganic film, and

the high refractive index portions in each of the at least two patterned organic films are line shaped, the high refractive index portion in an upper patterned organic film of the at least two patterned organic films and the high refractive index portion in a lower patterned organic film of the two patterned organic films are disposed to intersect each other.

7. The organic light emitting display device of claim 1, wherein the organic matrix and the high refractive index portions include a same material.

8. The organic light emitting display device of claim 1, wherein the display unit includes a first electrode on the substrate, an emission layer on the first electrode, and a second electrode on the emission layer.

9. The organic light emitting display device of claim 1, further comprising a capping layer between the display unit and the encapsulation layer.

\* \* \* \* \*

专利名称(译)	有机发光显示装置及其制造方法		
公开(公告)号	<a href="#">US9065076</a>	公开(公告)日	2015-06-23
申请号	US14/018912	申请日	2013-09-05
[标]申请(专利权)人(译)	三星显示有限公司		
申请(专利权)人(译)	三星DISPLAY CO. , LTD.		
当前申请(专利权)人(译)	三星DISPLAY CO. , LTD.		
[标]发明人	LEE HYUN SHIK KIM KYU SEOK		
发明人	LEE, HYUN-SHIK KIM, KYU-SEOK		
IPC分类号	H01L51/00 H01L51/52		
CPC分类号	H01L51/5275 H01L51/5268 H01L27/3244 H01L27/3272 H01L27/3274 H05B33/10		
优先权	1020130040926 2013-04-15 KR		
其他公开文献	US20140306193A1		
外部链接	<a href="#">Espacenet</a> <a href="#">USPTO</a>		

摘要(译)

一种有机发光显示装置，包括基板，基板上的显示单元，以及显示单元上的封装层，封装层包括多个交替的无机和有机膜，至少一个有机膜是图案化的有机膜薄膜和在有机基质中具有多个高折射率部分的图案化有机薄膜。

